

Operational **Manual**

Visible Spectrophotometer

SP-830+



Metertech Inc.
Version 1.08

Metertech Inc. provides this publication "as is" without warranty of any kind, either express or implied, including, but not limited to the implied warranties of merchantability or fitness for a particular purpose.

All rights are reserved, including those to reproduce this publication or parts thereof in any form without permission in writing from Metertech Inc.

Information in this publication is subject to change without notice and does not represent a commitment on the part of the vender.

Any errors or omissions which may have occurred in this publication despite the utmost care taken in its production will be corrected as soon as possible, but not necessarily immediately upon detection.

Copyright© Metertech Inc. 2004

Contents

Introduction	-----	3
Description	-----	3
Components	-----	3
Keyboard and display layout	-----	4
Rear panel layout	-----	5
Specifications	-----	6
Installation	-----	7
Standard equipment	-----	7
Environmental and electrical conditions	-----	7
Installation	-----	8
Operation	-----	10
Powering up the equipment	-----	10
Absorbance and Transmittance measurements	-----	10
Concentration measurement with a factor	-----	11
System functions	-----	12
Maintenance	-----	14
Routine care	-----	14
Replace the lamp	-----	14
Messages	-----	16
Replacement parts	-----	16

INTRODUCTION

Description

The model SP-830+ visible spectrophotometer is a digital microprocessor controlled instrument, providing photometric absorbance, transmittance and concentration measurements with the wavelength range of 320 to 999 nm. The spectrophotometer has the following unique features:

1. Two-line, 10-large character LCD display
2. Motorized optical filter wheel and grating
3. Multi-use sample compartment for square cuvettes, round tubes and 50mm longpath cells
4. Printer interface

Components

1. LCD display
2. Sample compartment door
3. Keyboard
4. Model name and company brand
5. AC adapter
6. Lamp compartment door

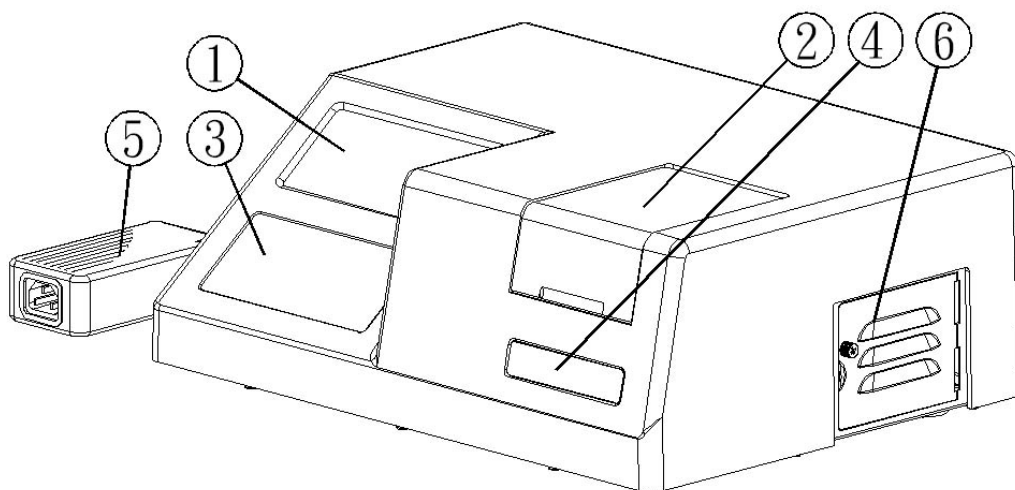

Figure 1: Components of SP-830+ spectrophotometer

Keyboard and display layout

1. **A/T/C** button: Switch between absorbance, %transmittance and concentration modes
2. **BLANK** button: Go to the entered wavelength, and then set the instrument to 100% transmittance, or zero absorbance or zero concentration
3. **PRINT** button: Send currently displayed data to printer
4. Wavelength buttons: Set the wavelength by pressing "**100**" button (showing 3 to 9), "**010**" button (showing 0 to 9), and "**001**" button (showing 0 to 9)
5. Display panel: 10 large characters by 2 lines LCD

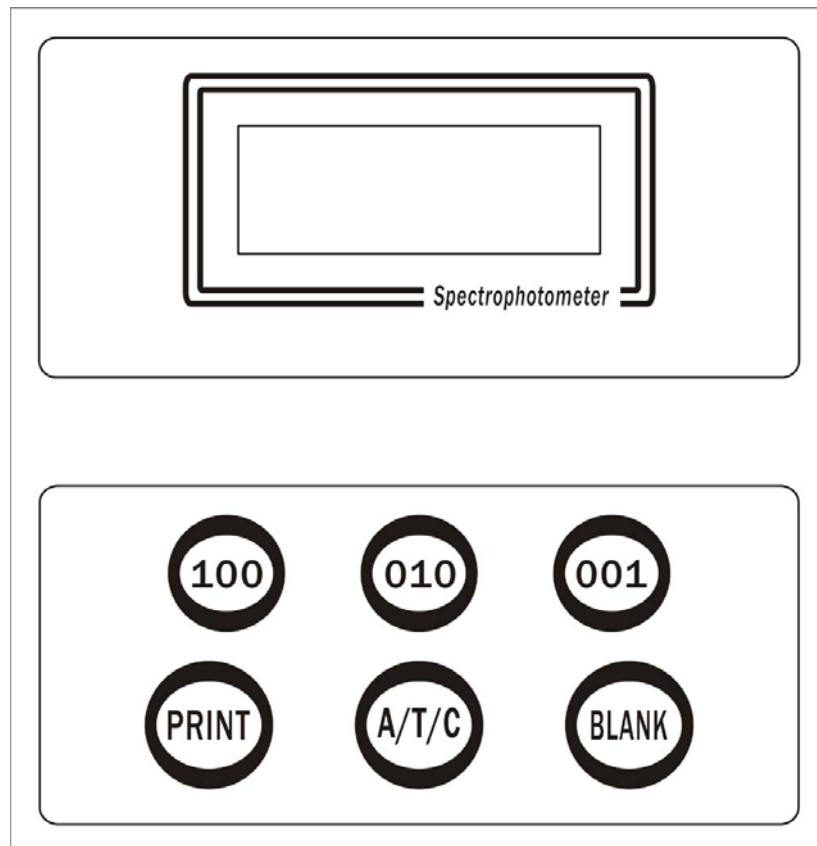

Figure 2: Keyboard and display layout

Specifications

Wavelength	320~1100nm
Bandwidth pass	5nm
Wavelength accuracy	+/- 0.1 nm
Wavelength repeatability	+/- 0.3 nm
Photometric range	-0.300 ~ 3.500Abs
Measurement mode	A / %T / C
Factor	0 ~ 9999
Photometric accuracy	1.0% or 0.003A(from 0.000 to 2.500A), whichever is greater by NIST SRM930e
Stability	< 0.003Abs/hr at 500nm after 3/4 hour warm-up
Stray light	< 0.1% at 340nm by NIST SRM2031
Light source	12V halogen lamp
Detector	Si photodiode
Wavelength scanning speed	4500nm/min
Cuvettes	10mm square cuvette, 10 ~ 13mm round tube, and 50mm rectangular cell
Light beam height	8.5mm at measurement position
Display	10 x 2 large characters LCD
Interface	Centronics parallel printer port
Function	Lamp tuning, system validation
Power	100 ~ 240V at 50/60Hz
Dimension	400(W) x 300(D) x 145(H) mm
Weight	7.5 kgs
Ambient temp/humidity	room temperature 15 ~ 35°C, humidity < 80%

Specifications subject to change without notice

INSTALLATION

Standard equipment

The package contains the item listed below. Unpack the carton and inspect carefully. If any part is damaged or missing, contact your dealer immediately.

<u>Qty</u>	<u>Description</u>
1	SP-830+ spectrophotometer
1	AC adaptor
1	Power cord
1	Operator's manual
5	10mm plastic square cuvette
1	Dust cover

Environmental and electrical conditions

The instrument has been designed to operate and meet the specifications on previous pages under the electrical and environmental requirements listed below.

Line voltage

100-240Vac, 50-60 Hz

Environment conditions

Ambient temperature from 15°C to 35°C and maintained at +/- 2°C; relative humidity from 20% to 80% and maintained at +/-5%.

Installation

1. Place the spectrophotometer on a solid and level surface in a dry, clean environment.
2. Leave an open space at least 50mm distance from rear panel and side walls to guarantee air flow around the instrument.
3. Connect the female end of power cord into the inlet of AC adapter, and then the outlet plug of AC adapter into the DC input hole on the rear panel of instrument.
4. Plug the power cord into a grounded wall outlet with the appropriate voltage.
5. Connect the Centronics parallel printer to the instrument at the print port.
6. Turn on the power switch and allow instrument to warm up at least 30 minutes for electronic and thermal stabilization.
7. The standard cell holder is adaptable for 10 mm square cuvette and 1/2" round tube. For 50 mm long-path cell measurement, please unscrewing two white knobs (#1) and removing metal bracket (#2) inside the sample compartment as shown in the following drawings, then tighten two knobs again.

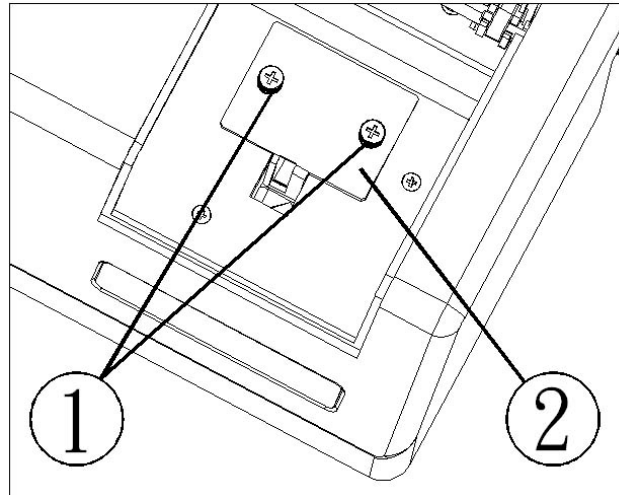

Figure 4a: Standard sample holder for 10-13 mm cuvettes

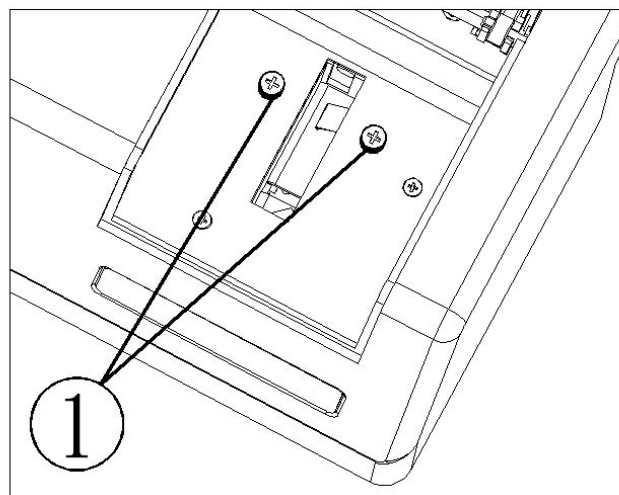

Figure 4b: 50 mm rectangular cell holder

OPERATION

Powering up the instrument

1. Empty the cell holder and close the cell compartment lid.
2. Power on the SP-830+ spectrophotometer, LCD shows "SP-830+, Metertech" for 2 seconds.
3. Then "Initialize, Zeroing..." for monochromator and filter wheel initialization. It takes less than one minute to finish optical zero-search.
4. Then go to default wavelength 500nm with unit "ABS" for the first time operation.
5. The instrument will automatically "**BLANK**" at this wavelength and displays "500nm, 0.000A".
6. Allow the instrument to warm up for 30 minutes before using it.

Note: Error–1 message with beeping may show up, if there is sample in cell holder or lid is opened during initialization. Please power off machine, correct the mistake , and power on again.

Absorbance and Transmittance measurements

1. Press "**A/T/C**" to select the absorbance or transmittance mode.
2. Press "**100**" or "**010**" or "**001**" to enter the wavelength.
3. Insert blank solution into the cell holder and close the sample compartment lid.
4. Press "**BLANK**". LCD shows wavelength change to target number, then "Blank..." on lower screen and then "100.0 %T" or "0.000A".
5. Remove blank solution and insert sample solution in the cell holder. The sample reading is real-time showing on the display.
6. Press "**PRINT**" to print out the wavelength and reading shown on the screen.

Note: While powering off, the latest keyed in wavelength and unit (A/T) will be saved in memory, and used as initial value for next powering up.

Concentration measurement with a factor

1. Press "**A/T/C**" to select the concentration mode.
2. Press either "**100**" or "**010**" or "**001**" one time to show current factor "F=XXX".
3. Then press the above three numerical keys to enter a factor value (0-999).
4. Insert blank solution into the cell holder and close the sample compartment lid.
5. Press "**BLANK**" to set "0.000C".
6. Remove blank solution and insert sample solution in the cell holder. The sample measurement appears on the display.
7. Press "**PRINT**" to print out the wavelength, factor and reading shown on the screen.
8. User can press "**A/T/C**" to other mode, or go to step 2 to enter new factor, or step 5 to "**BLANK**" again.

Note:

- If wavelength needs changing in concentration mode, please go to A/T mode first to key in the number and "**BLANK**". Then follow the above procedure.
- While power off the instrument, the current keyed-in factor will be saved in memory and used as initial value for following powering on.

System functions

There are three options available in system functions. In order to get into these functions, empty cell holder and press either "100" or "010" or "001" one time at A/T mode (not C mode) to show numerical digit blinking. Then Press "PRINT" four times to get "Function, 1: Validate" on LCD display. Press "A/T/C" repeatedly will display each option sequentially as explained below.

1: Validate

- Press "BLANK" to show "[3] BW, [2] WL Err".
- Press "100" for optical bandwidth measurement. The machine goes to zero position and takes measurement. The result shows "Measure BW, BW: X.XX nm".
- Press "010" and start to measure wavelength accuracy at 361nm and 536 nm by a built-in HY-1 filter. The result shown on display is "361 536, X.X X.X". X.X represents difference between actual wavelength and ideal wavelength.
- Press "A/T/C" twice to the next option.

2: TuneLamp

- Please see the explanation starting from step 7 of section "Replacement the lamp".
- Press "A/T/C" to the next option.

3: Ver X.X

The software version of this machine is shown here. Press "A/T/C" to return to the first option.

Note:

- Data viewed in system validation can be printed out by pressing "PRINT".
- To return to measurement mode, press "001" four times and go to the latest wavelength.

4: Change Abs, %T Resolution

- After initialize, when the SP-830+ enter main screen
- Press any number key (001, 010, 100)
- Press Print key 4 times to enter function menu
- Press the A/T/C key until the LCD shows 3: Resolute
- Press Blank to switch between "High" resolution, and "Low. resolution
- Press A/T/C key to confirm and return to function menu
- Press 001 key 4 times to go back main screen

5: Change display units

- After initialize, when the SP-830+ enter main screen
- Press any number key (001, 010, 100)
- Press Print key 4 times to enter function menu
- Press the A/T/C key until the LCD shows 4: Conc
- Press Blank key to switch between C,ppm, ppb, g/L, mg/L, mg/dL, mg/mL, g/L, U/L, M, mM, uM, IU display units
- Press A/T/C key to confirm and return to function menu
- Press 001 key 4 times to return main menu

MAINTENANCE

Routine care

Very little maintenance is required to keep the instrument in good working condition. The interior should be kept as dust free as possible and the sample compartment cleaned regularly; wipe off spilt chemicals immediately.

WARNING: Do not remove the cover of the instrument.

CAUTION: Do not allow moisture to leak into the instrument.

The exterior of the instrument can be cleaned periodically as follows:

- ◆ SWITCH OFF first the instrument and disconnect from the mains supply.
- ◆ Using a lint free cloth dampened with a weak solution of detergent and water, wipe the exterior surface of the instrument as necessary.
- ◆ Wipe over with a soft cloth dampened with clean water.
- ◆ Dry the surface with another soft cloth.

Replace the lamp

CAUTION: Switch off and disconnect the instrument from the mains supply and allow the lamp to cool down at least 10 minutes before proceeding.

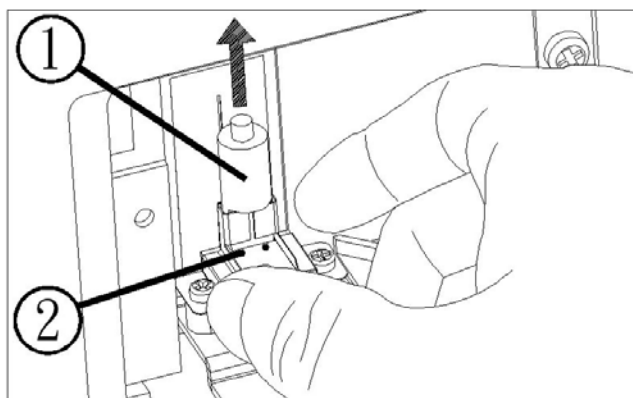

Figure 5a: Lamp change

WARNING: Do not touch lamps with bare hands. Use glove or cloth to prevent staining of the bulb.

WARNING: Pay extreme attention not to touch parts other than those as instructed.

1. Turn off and unplug the instrument.
2. Allow the lamp to cool for at least 10 minutes.
3. Open the lamp door on the right side of instrument by loosening the knob in counterclockwise direction.
4. Pull the old lamp (#1) straight up to remove it from socket as shown in the figure 5a above
5. Hold a new lamp with tag at flat portion facing to user, then remove the tag. Align the two legs of new lamp with the two holes (#2) in the socket, and press the lamp securely into the socket.
6. Carefully wipe off any fingerprints on the lamp with a soft tissue.

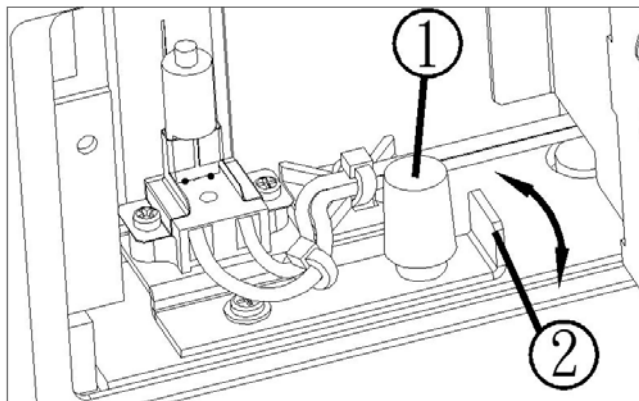

Figure 5b: Lamp tuning

7. Power up the instrument by following previous instruction.
8. Empty cell holder, press either "100" or "010" or "001" one time at A/T mode (not C mode) to show numerical digit blinking.
9. Then press "PRINT" four times. The display shows "Function, 1: Validate". Then press "A/T/C" and LCD shows "2: TuneLamp".
10. Press "BLANK" and go to zero position. LCD then shows "Tune Lamp, XXX".
11. In the lamp house (see figure 5b), loosen the white thumbscrew (#1) and adjust the vertical flange (#2) close to it forward/ backward. The displayed number XXX will vary in accordance with flange movement. Find the largest number and tighten the thumbscrew.
12. Close the lamp door with knob tightened. Power off and Power on again the instrument to complete lamp alignment.

Messages

This section lists messages for errors or abnormal conditions during operation.

- Error-0 Grating photo-interrupter or grating motor has malfunctioned, call for service.
- Error-1 Light source is not functioning or too weak/ bright, change with proper lamp supplied by original manufacturer.
- Error-2 Grating motion exceeds lower limit, call for service.
- Error-3 Grating motion exceeds upper limit, call for service.
- Beep Beeping while blanking with lid open or blanking solution absorbance greater than 1.5A, or while sample reading with absorbance greater than 4.0A. The beep will continue until the condition is resolved.

Replacement parts

<u>Part#</u>	<u>Description</u>
0960870100	Tungsten-halogen lamp, package of 2
A00001-1	10mm plastic square cuvette, package of 100
A00003	1/2" glass round tube, package of 6
0770870100	AC adapter for SP-830+ spectrophotometer
OP830P	SP-830+ spectrophotometer operational manual